

Capitol Energy Systems TWC48 Standard Gas/Electric HVAC System Wiring

Thermostat back

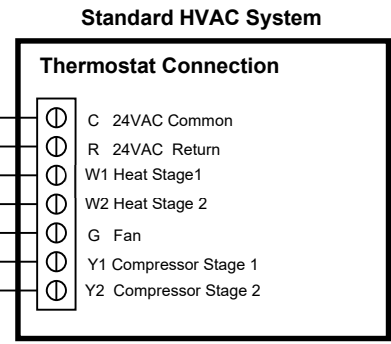
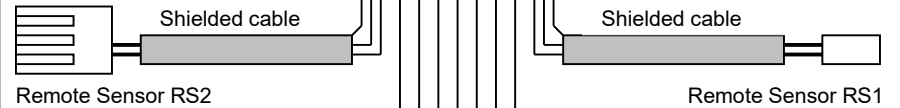
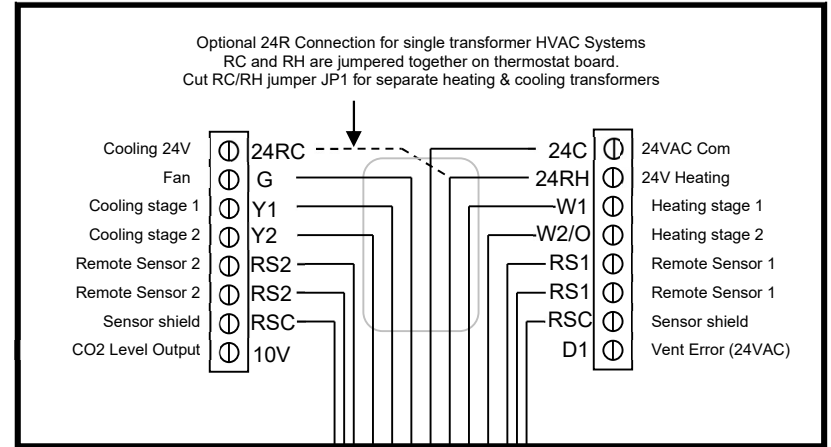

Thermostat Setup:

Standard Gas/Electric HVAC Systems

To set the HVAC system type, go to the Main Menu *Thermostat Info* screen and *press and hold* the **Setup** button.

1. **Type.** Set the HVAC System Type: set to **Gas/Elec**
2. **Fan Type.** Set the HVAC Fan Type:
Set to **Gas** for typical gas furnace (fan is controlled by the furnace)
Set to **Elec** for electric heat (fan call with heat call)
3. **2nd Stage Heat.** Enable second stage heating outputs
If you have a single stage heating system, leave this set to **N**
If you have a 2 stage heating system, set to **Y** to enable.
4. **2nd Stage Cool.** Enable second stage cooling outputs
If you have a single stage cooling system, leave this set to **N**.
If you have a two stage cooling system, set to **Y** to enable.

- Default Setup:
- HVAC Type: Gas/Elec
 - Fan Type: Gas
 - 2nd Stage Heat: No
 - 2nd Stage Cool: No
- No setup required for this configuration

Capitol Energy Systems TWC48 Heat Pump HVAC System Wiring

Thermostat back

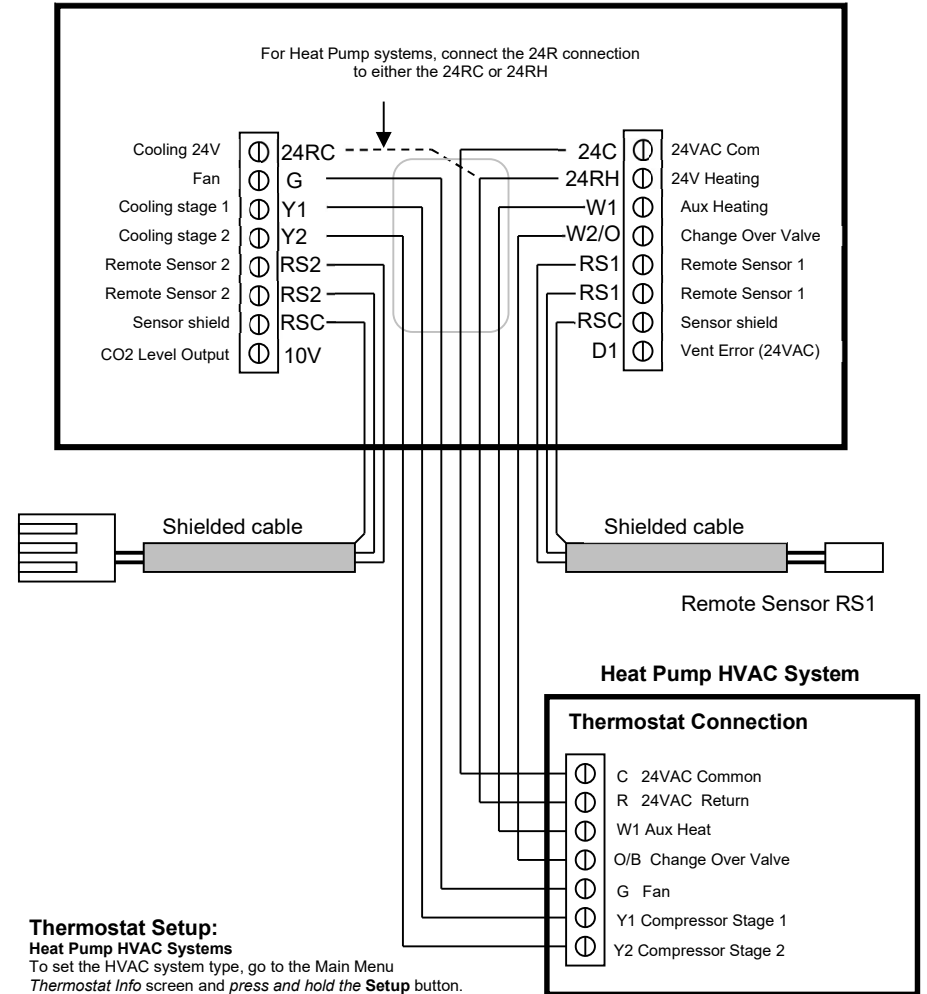

Thermostat Setup:

Heat Pump HVAC Systems

To set the HVAC system type, go to the Main Menu
Thermostat Info screen and press and hold the Setup button.

- Type.** Set the HVAC System Type: set to **Heat Pump**
- C/O type.** Change Over (reversing) Valve Type. Heat pumps change from heating to cooling by reversing operation. You must configure the thermostat's changeover valve setting to work correctly with your HVAC system. Check your system information to be sure and note the color of original thermostat wire and the terminal it was connected to. No matter what the old stat connection was (O or B), connect the wire to the thermostat's W2/O terminal. The setting of the C/O Type will set the correct system operation.
For change over with cool systems (Orange wire, O terminal): set **C/O type** to w/cool (most common and default setting)
For change over with heat systems (Brown wire, B terminal): set **C/O type** to w/heat
- 2nd Stage Heat.** Enable second stage heating outputs
If you have a single stage heating system, leave this set to **N**
If you have a 2 stage heating system, set to **Y** to enable.
- Aux Heat (HP).** If you have auxiliary heat strips, set this to **Y** to enable.
- 2nd Stage Cool.** Enable second stage cooling outputs
If you have a single stage cooling system, leave this set to **N**.
If you have a two stage cooling system, set to **Y** to enable.

Note! If you get heating when you expected cooling, change the C/O type to the opposite setting.